

Overview 2**Hardware Setup 2**

Card Configuration 3

Card Connection 7

CE Compliance 8

DaqBook and DaqBoard [ISA type] Configuration 8

Software Setup 9**Hardware Function 9**

Input Signal Conditioning 9

Edge Selection 11

Debouncing 11

Frequency Measurement 11

D/A Conversion 12

Specifications - DBK7..... 13**Reference Notes:**

- Refer to [Chapter 2, *Power Management*](#), in regard to calculating system power requirements.
- [Chapter 3, *System Connections and Pinouts*](#), includes pinouts for P1, P2, P3, and P4. Refer to the pinouts that are applicable to your system, as needed.

Overview

The DBK7 can be used for diverse frequency-monitoring applications. Typical uses include measuring the flow of liquids with a flowmeter and measuring rotation (rpm) with a shaft encoder. The monitored process must generate a series of electrical pulses whose frequency is related to the desired variable.

Features of the DBK7 include:

- Inputs can be analog (high or low level) or digital.
- Each channel has a programmable frequency range.
- Noise effects can be minimized by debounce, attenuation, and low-pass filtering.
- Up to 64 DBK7s can be used with a single LogBook or Daq device for a maximum of 256 channels.

The card's basic function can be realized from the following block diagram. Each channel:

- Conditions an input signal
- Selects the signal's rising or falling edge
- Debounces the edge
- Measures the signal's frequency.

The D/A converter outputs a voltage from -5 V to +5 V to correspond with the selected frequency range. The LogBook directs the card's D/A converter to convert the data from the proper input channel.

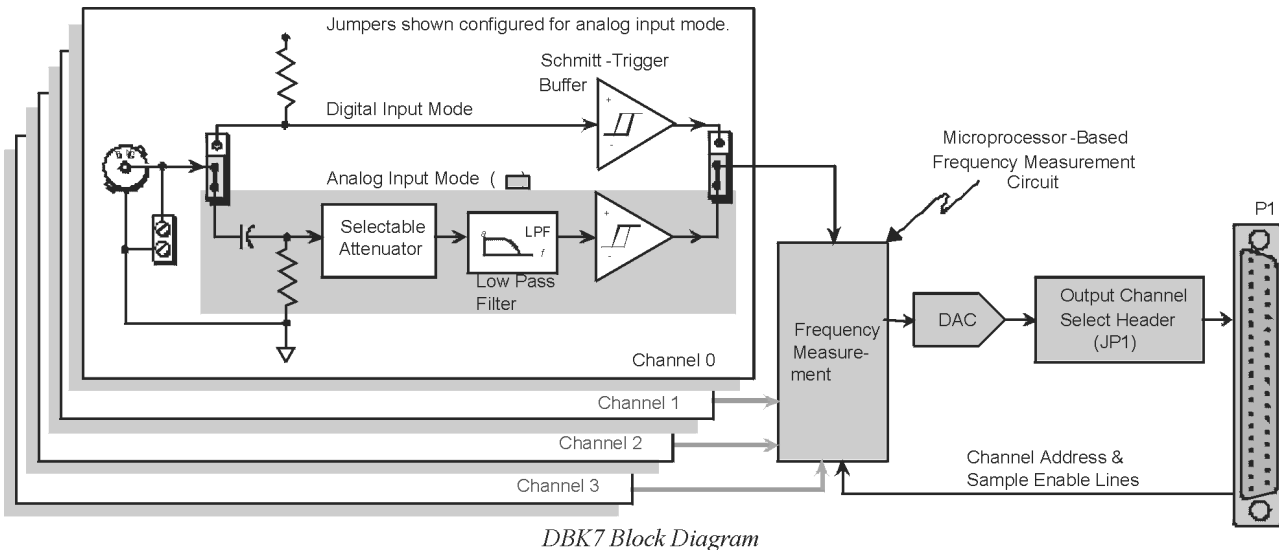

Hardware Setup

CAUTION



DBK7 must be configured before connecting the card to inputs and outputs. Failure to do so could result in card damage.

Hardware-related steps for setting up DBK7 include:

- Configuring the DBK7 onboard jumpers and switches for the application (see previous CAUTION).
- Configuring the Daq device (see page 8)
- Connecting the input cables to sensors and the output cable to a Daq device or LogBook.

Card Configuration

Several jumpers and one switch must be set on the DBK7 card to match both the system setup and the signal-conditioning requirements. This section describes a typical configuration. The following table indicates the factory default settings of each jumper. The below figure shows the location of the jumpers and DIP-switch (S1).

Factory Defaults for DBK7 On-board Jumpers		
Configuration	Jumpers	Applies to ...
Channel Selection , pg. 4 <ul style="list-style-type: none"> The default is channel 0 Up to 4 cards can share the same J1 channel. See switch S1 information in regard to card selection. 	J1	16 Channels
Input Circuit Selection , pg. 6 <ul style="list-style-type: none"> The default is Analog Input Each jumper connects pins 1 and 2 	JP3 and JP4	CH 0
	JP23 and JP24	CH 1
	JP43 and JP44	CH 2
	JP63 and JP64	CH 3
Attenuation Selection , pg. 6 <ul style="list-style-type: none"> The default is Attenuation Enabled (reduced sensitivity) Each jumper connects pins 1 and 2 	JP1	CH 0
	JP21	CH 1
	JP41	CH 2
	JP61	CH 3
Low Pass Filter Selection , pg. 7 <ul style="list-style-type: none"> The default is 100 kHz Each jumper connects pins 1 and 2 	JP2	CH 0
	JP22	CH 1
	JP42	CH 2
	JP62	CH 3

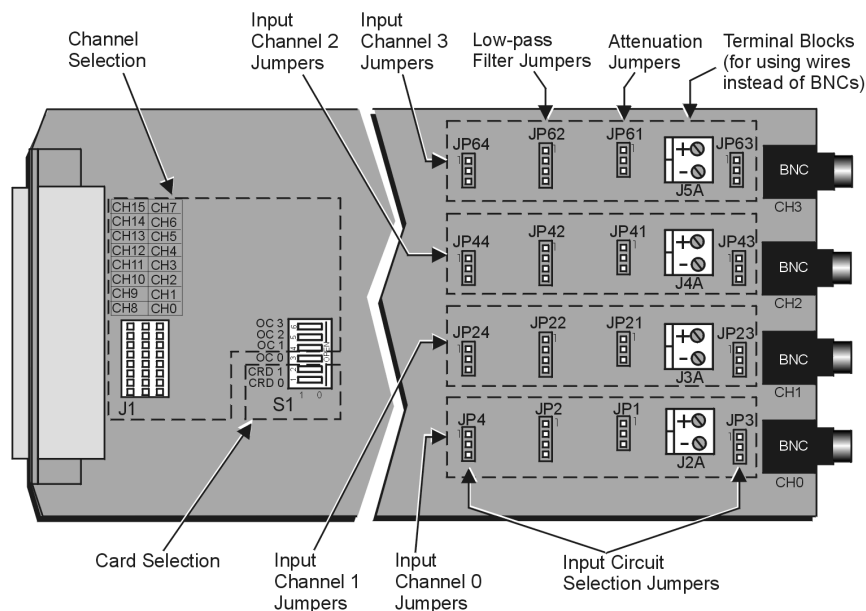

DBK7 Board Layout

Channel and Card Selection Configuration (J1 and S1)

Up to 4 DBK7 cards can connect to a single main channel. Thus, a 16-channel LogBook or Daq device can connect to 64 DBK7 cards. Since each card has 4 input channels, a fully populated system can use 256 input sensors. To keep these inputs organized, the card is configured by physically setting a jumper (J1) and a DIP switch (S1).

- **J1** is a 24-pin (3×8) header requiring two pins in a row to be connected. Up to 4 cards can share the same channel.
- **S1** is a 6-position DIP switch (positions 3-6 set the main channel). Each card sharing a main channel can have one of four sub-addresses (card number) as set by S1 (positions 1 & 2).



J1, S1, and the software must all be set to the same channel.

Set the main channel and sub-address as follows:

1. Determine the main channel and card number for each DBK7 used. It may be necessary to check the software setup and other cards in the system to avoid a conflict. Note that a DBK7 may share a channel with 3 other DBK7s. Each card sharing a LogBook or Daq device base channel must use a unique card number sub-address.
2. Set the J1 jumper across the 1st and 2nd or the 2nd and 3rd pin of a row to the desired channel. Refer to the silk screening just above the jumper for proper positioning (see previous figure).
3. Set S1 DIP switches 3-6 (OC0 to OC3) to match the channel selected on J1, and verify both settings (S1 and J1) are correct (see previous figure).
4. Set S1 DIP switches 1 & 2 (CRD0 and CRD1) to give the card a unique sub-address with the chosen main channel. Any unused sub-address in the range 0-3 is valid (see following figure).

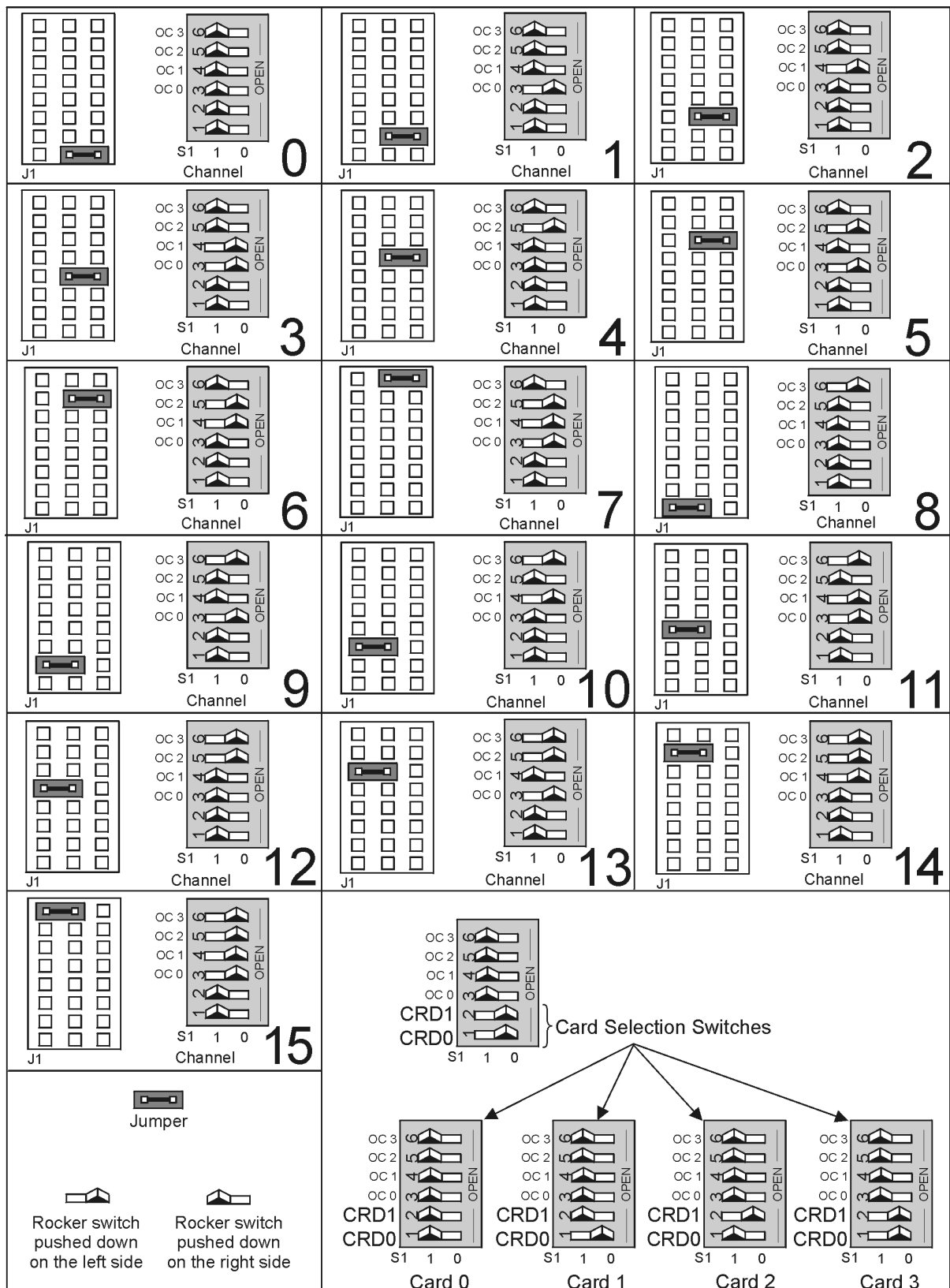

DBK7 Channel Configuration

Note: Each of the 16 main Daq* channels can support 4 DBK7 cards; and each DBK7 card can support 4 analog channels. Both J1 and S1 (3-6) select the main channel (they must match). S1 (1-2) selects the card. **Every card must have a unique address of channel and card.**

Input Signal Conditioning Configuration

Hardware settings affect 3 aspects of signal conditioning:

- Input circuit selection: analog or digital
- Attenuation selection
- Low-pass filter selection.

Input Circuit Selection

Each input channel can be set for the analog or digital circuit. Two jumpers must be set for each channel.

Select the input circuit for each input channel as follows:

1. Determine the best circuit type for each channel.
 - The digital input circuit works best for DC-coupled signals where the low level is less than 0.5 V and the high level is above 2.5 V and the voltage does not exceed ± 15 V. By using a pull-up resistor, switches and relays can create the signal. Frequencies can be as high as 960 kHz. The digital input circuit does not attenuate or filter the input signal.
 - The analog input circuit is AC-coupled and is sensitive to signals from 100 mV to 84 V p-p. It also provides attenuation and low-pass filtering to reduce the effects of noise.
2. Position the input circuit jumpers for analog or digital (see figure). Verify that both jumpers for a channel are set the same (JP3 and JP4 for channel 0; JP23 and JP24 for channel 1; JP43 and JP44 for channel 2; and JP63 and JP64 for channel 3).

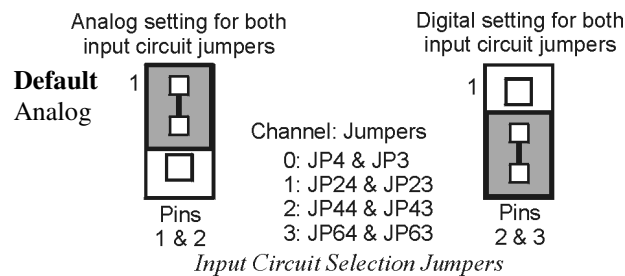

Attenuation Selection (Analog Input Circuit Only)

When measuring strong analog signals, the attenuator can reduce the input sensitivity and the effects of noise. If enabled, the attenuator reduces the input sensitivity by a factor of about 20.

Set the attenuation for each channel as follows:

1. Determine the best attenuation for each channel.
 - Use attenuation and reduced sensitivity if the input signal's peak level exceeds 1 V.
 - Disable attenuation for full sensitivity if the input signal's peak level is less than 1 V.
2. For attenuation, position the jumper across pins 1 and 2. Attenuation is enabled (the default setting). (See figure.)

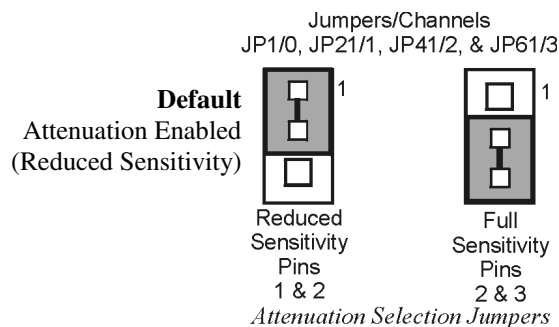

3. To disable attenuation, position the jumper across pins 2 and 3. The full-strength signal is used.

4. Verify the jumper position for each input channel.
 - **JP1 for channel 0**
 - **JP21 for channel 1**
 - **JP41 for channel 2**
 - **JP61 for channel 3**

Low-Pass Filter Selection (Analog Input Circuit Only)

The low-pass filter removes high-frequency noise that could otherwise fool the DBK7 into detecting a higher frequency. To set the low-pass filter:

1. Determine the highest frequency you expect to measure on each input channel.
2. Select the next higher cutoff frequency (30 Hz, 300 Hz, or 100 kHz) for each corresponding channel (see figure *Typical Sine-Wave Sensitivity vs Frequency* later in this section). Verify that the DBK7's sensitivity will accommodate the expected input signal strength.
3. Set jumpers for low-pass filter selection.
 - **JP2 for channel 0**
 - **JP22 for channel 1**
 - **JP42 for channel 2**
 - **JP62 for channel 3**

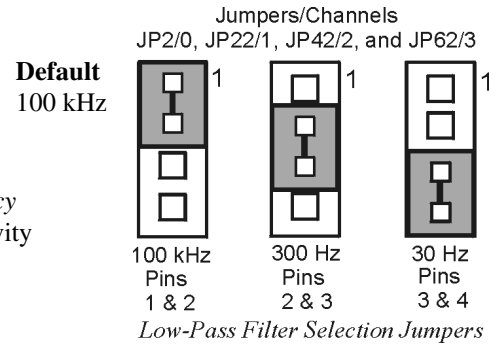

Card Connection

After the DBK7 hardware is configured, the card can be safely connected to the signal inputs and to the primary acquisition device. You can connect up to four sensors to the DBK7's input BNC connectors. A CA-37-x (or CA-131-x) cable is used to connect the card to a LogBook or Daq device [possibly through an expansion module] via the card's DB37 connector. Connection steps follow.

WARNING



Electric shock hazard! Do not exceed a sensor input of 30 Vrms (42 Vpeak, 84 Vp-p) for analog or ±15 Volts for digital. Exceeding these values may present an electric shock hazard that could possibly result in injury or death, in addition to DBK7 damage.

Connect the DBK7 card as follows:

1. Connect each sensor's BNC connector to a mating connector on the card. Channel labels (CH0 to CH3) are printed just below the corresponding connector. Label each sensor with its corresponding channel, card sub-address, and DBK7 input channel.
2. For a single DBK7 card, connect one end of the P1 cable to the card's male DB37 output connector.
 - For DaqBook applications - use a CA-37-1 cable
 - For DaqBoard/2000 Series or /2000c Series boards - use a CA-37-1 with a DBK200 Series adapter
 - For DaqBoard [ISA type] boards - use a CA-131-1 cable
 - For Daq PC-Card, use a CDK10 (expansion, power module) with CA37-1 and CA-134 cables.

3. Connect the other end of the cable to the P1 port of the LogBook or Daq device. For multiple DBK7 cards, use a CA-37-x (or CA-131-x) cable to daisy-chain several cards or an expansion module. For example, three DBK7s (or 2 DBK7s and an expansion module) can be connected to a LogBook or a Daq device with a CA-37-3.
4. For multiple cards from a Daq PC-Card, cable CA-134 must first connect to an expansion module (a CDK10 or a DBK41 with a DBK33 power card) then through a CA-37-x to the DBK7s.

Note: For longer cable runs, use a CA-113 to add 6 ft of cable length where needed.

CE Compliance

If your data acquisition system needs to comply with CE standards, the DBK7 must be placed in a DBK41/CE 10-slot analog expansion module that is connected to the LogBook or Daq device by a CA-143-x cable.

Note that in the presence of 3 V/m RF fields, the following conditions must exist in order to meet CE requirements:

- 500 mVpp signals are required to maintain 0.1% accuracy.
- Metal shells of the BNC connectors must be directly connected to the chassis ground in order to maintain 100 mV sensitivity and 0.1% accuracy.
- The host computer must be properly grounded.
- The host computer and peripheral equipment must be CE compliant.



Reference Notes: If your data acquisition system needs to comply with CE standards, refer to the following:

- The [CE Compliance](#) section of Chapter 1.
- The [DBK41](#) document module.



DaqBook and DaqBoard [ISA type] Configuration

Several setup steps of DaqBooks and DaqBoards [ISA type] are required to use DBK7 cards in a system.

1. If not using auxiliary power, place the JP1 jumper in the expanded analog mode.

Note: This default position is necessary to power the interface circuitry of the DBK42 via the internal ± 15 VDC power supply. If using auxiliary power (DBK32A/33), you must remove both JP1 jumpers (refer to chapter 2, [Power Management](#) and the DBK32A/33 modules).

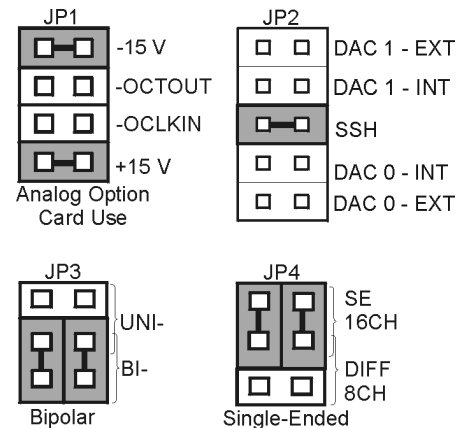

DaqBook/DaqBoard Settings for DBK7

CAUTION



When using the SSH output, do not use an external voltage reference for DAC1. Applying an external voltage reference for DAC1, when using the SSH output, will result in equipment damage due to a conflict on P1, pin #26.

2. Place the JP2 jumper in the SSH position (See previous CAUTION).
3. **For DaqBook/100, /112 and /120 only**, place JP3 jumpers in *bipolar mode*.
4. **For DaqBook/100, /112 and /120 only**, place JP4 jumpers in *single-ended mode*.

Software Setup



Reference Notes:

- **DaqView users** - Refer to [Chapter 4, DBK Setup in DaqView](#).
- **LogView users** - Refer to [Chapter 5, DBK Setup in LogView](#).

Hardware Function

This section explains DBK7 functions that affect user settings to ensure the best performance. For setup questions or noise problems, refer to the related section. The figure provides an overview of signal conditioning function blocks and can be referred to for the following discussions.

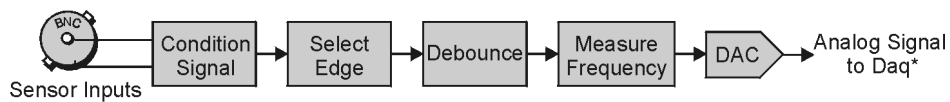

DBK7 Function Diagram

Input Signal Conditioning

The DBK7 conditions the input signal in several ways to provide the best output accuracy. Reducing noise and limiting the bandwidth are the first steps in the conditioning process and are done in hardware. Software can further clean up the signal by selecting the cleanest edge to read and by setting a debounce delay to ignore spurious signals.

Analog Input Signal Conditioning

The equivalent analog input circuit is shown in the figure. Input voltages should be at least 50 mV peak-to-peak. The maximum analog input signal is 30 Vrms (42 Vpeak, 84 Vp-p). Stronger signals may damage the DBK7 or present an electrical shock hazard.

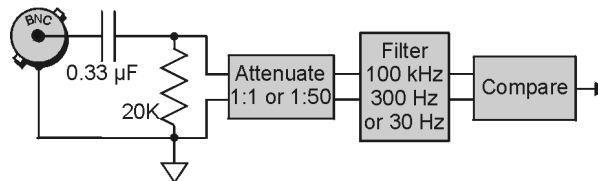

DBK7 Analog Equivalent Input Circuit

When the input circuit jumpers are set for analog, the center conductor of the BNC connector is AC-coupled through a 0.33 μF capacitor to the attenuator. The outside conductor connects directly to ground. With the attenuator disabled for full sensitivity, input-protection diodes limit the signal to about 1.5 Vp-p. Larger signals will see an impedance of 6.7 $\text{K}\Omega$ (rather than 20 $\text{K}\Omega$) in series with 0.33 μF . With the attenuator enabled, the input impedance remains 20 $\text{K}\Omega$ regardless of the input level.

After AC-coupling, attenuation and filtering, a comparator converts the input signal into a clean digital signal. The comparator output is high when the center-pin signal is higher than the outside-conductor signal (and low when the center-pin is lower). The comparator has hysteresis to reduce the effects of noise by ignoring small signals.

The following graph shows typical sine-wave sensitivity in peak-to-peak voltage vs frequency. Six combinations of attenuation (on/off) and low-pass filtering (30 Hz, 300 Hz, and 100 kHz) are graphed.

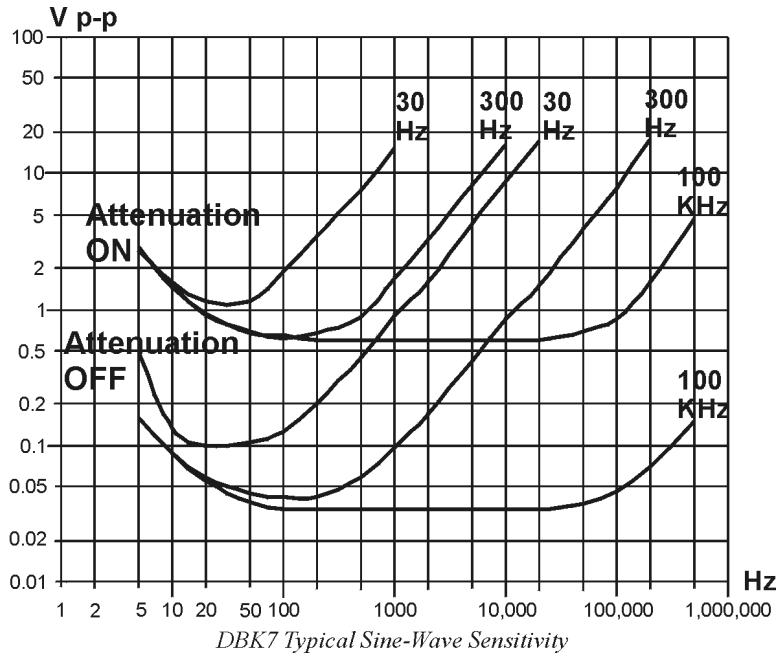

Digital Input Signal Conditioning

The equivalent digital input circuit is shown in the figure. The input signal may range from -15 to +15 V. Higher voltages may damage the DBK7.

When the input circuit jumpers are set for digital, the outside (shield) conductor of the BNC connector connects directly to ground. The center conductor is pulled up with 27 K Ω to +5 V and then passes through a 2.7 K Ω protection resistor before being detected by a Schmitt-trigger buffer with input-protection diodes.

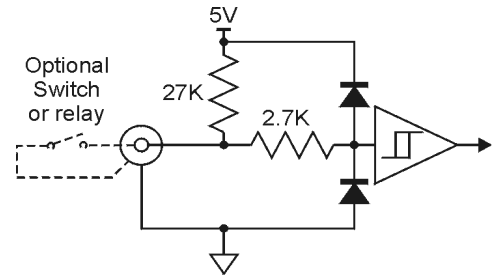

DBK7 Digital Equivalent Input Circuit

The input thresholds are fixed TTL levels. Below 0.5 V (0.8 V typical), the Schmitt-trigger buffer output is low. Above 2.1 V (1.6 V typical), the buffer output is high. The 27 K Ω pull-up resistor allows the digital inputs to sense switches or relays connected directly to the DBK7 as shown in the figure. The debounce circuit can remove noise effects of switching.

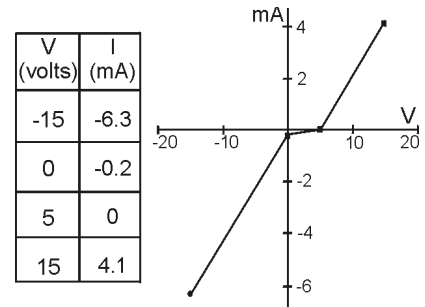

DBK7 Digital I/V Relationship

The input impedance for digital signals depends on the signal level. For signals between 0 and 5 V, the input-protection diodes do not conduct, and the digital input impedance is just the 27 K Ω pull-up resistance. For signals less than 0 V or greater than 5 V, the input-protection diodes conduct and the impedance drops to about 2.4 K Ω . The figure shows the approximate digital-input current/voltage relationship.

Edge Selection

The DBK7 determines the frequency by measuring the time between successive rising or falling edges of the input signal. Which edge is electrically cleaner depends on the application and related components. If rising edges are used, the edge-selection circuit does not modify the signal. If falling edges are used, the circuit inverts the signal so falling edges appear as rising edges to the subsequent circuits. Through software, each channel can be independently set for rising- or falling-edge.

Debouncing

Debouncing is a process of ignoring signals too short to be real events. When a relay or switch closes, the electrical contacts may not initially make good contact. Mechanical vibrations can occur, and contact is made and broken several times stabilizing. Counting all these signals would yield too high a frequency. The debounce circuit solves this problem by ignoring rising edges not preceded by a sustained low signal. The sustain interval can be set in software to 0, 0.6, 2.5, or 10 ms for each channel. Debouncing may be disabled (0 ms) for clean, high-frequency signals. Long debounce times will limit high-frequency response (e.g., a 10 ms debounce will limit the frequency to about 100 Hz). In general, use “0” (debounce disabled) for clean, high-frequency signals; increase the debounce as needed for noisy, low-frequency signals from switches and relays.

The figure shows the effect of 10 ms debouncing on a noisy signal. To be counted, a rising edge must be preceded by a low sustained for at least 10 ms without any other edges. Rising edges **a** and **f** are counted because they are preceded by low signal levels sustained for at least 10 ms (the debounce time). All other rising edges (**b**, **c**, **d**, and **e**) are ignored. Any falling edge makes (or keeps) the debounced output low, regardless of preceding edges. Thus, the DBK7 can detect short pulses even with debouncing.

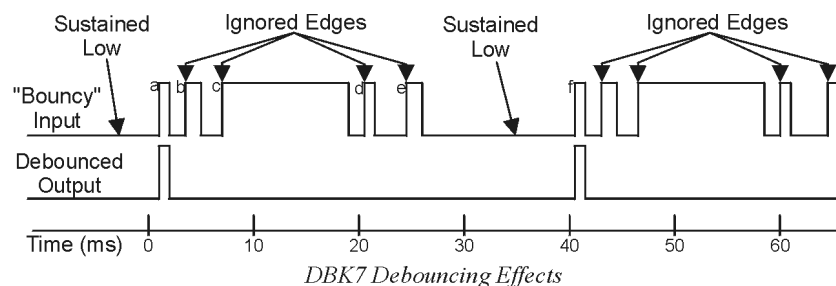

Frequency Measurement

After debouncing, the signal's frequency is ready to be measured. Frequencies are measured to 12-bit accuracy between a minimum frequency (F_{\min}) and maximum frequency (F_{\max}). This frequency range can be programmed individually for each channel. The limitations on F_{\min} and F_{\max} are:

- The frequency range must be within 0 to 1 MHz.
- $F_{\max} - F_{\min}$ must be at least 1 Hz.
- F_{\max} / F_{\min} must be at least 100/99 (1.010101).

Based on F_{\min} and F_{\max} , the DBK7 measures the frequency by counting input cycles during a variable time interval. The length of the interval depends on the difference between F_{\min} and F_{\max} .

- For a wide range (when F_{\min} and F_{\max} are far apart), each bit of the 12-bit result represents a large frequency change and can be measured quickly.
- For a narrow range (when F_{\min} and F_{\max} are close together), each bit of the 12-bit result represents a small frequency change and takes longer to measure.

The following equation determines the time interval needed to measure a frequency:

$$\text{Minimum Measurement Period (sec)} = (4096 \times 0.5 \mu\text{s}) [F_{\text{max}} / (F_{\text{max}} - F_{\text{min}})]$$

In this equation: 4096 derives from 12-bit precision; 0.5 μs is the resolution of the DBK7's timing circuits; and $F_{\text{max}} / (F_{\text{max}} - F_{\text{min}})$ is the ratio the measurement time must be increased to achieve 12-bit accuracy over the selected range.

To see how the measurement period varies, consider two examples:

- To measure frequencies from 59 to 61 Hz, the measurement period is at least $4096 \times 0.5 \mu\text{s} \times 61/2 = 62.5 \text{ ms}$, or about 16 measurements per second.
- To measure frequencies from 1 to 61 Hz, the measurement period is at least $4096 \times 0.5 \mu\text{s} \times 61/60 = 2.1 \text{ ms}$. Note that as the DBK7 only measures frequency once per cycle, it would take from 1 to 61 measurements per second.

Thus, measuring frequencies over a narrow range takes longer than over a wide range as the ratio of $F_{\text{max}} / (F_{\text{max}} - F_{\text{min}})$. The actual measurement time is the sum of several items: the minimum measurement period (from the equation above), the actual input period, and a variable processing time of 0 to 4 ms.

Note: If the Sequence Rep Rate is set faster than the measurement rate, multiple readings of the same measurement will occur.

After the frequency (F) is measured to the required accuracy, it is scaled to a 12-bit number (D) for use by the Digital to Analog Converter (DAC). This 12-bit number is determined by the formula:

$$D = 4096 [(F - F_{\text{min}}) / (F_{\text{max}} - F_{\text{min}})]; \text{ where: } 0 < DAC < 4096$$

If the measured frequency is F_{min} , then the scaled result is 0. If the measured frequency were F_{max} , then the scaled result would be 4096 but is limited to 4095. Measured frequencies below F_{min} are scaled as 0; frequencies above F_{max} are scaled as 4095. The highest frequency that produces an accurate result is the one that converts to a DAC value of 4095; that is, $F_{\text{min}} + 4095/4096 (F_{\text{max}} - F_{\text{min}})$ which is the same as $F_{\text{max}} - 1/4096 (F_{\text{max}} - F_{\text{min}})$.

D/A Conversion

The 12-bit scaled result is stored in the DAC to be read by the data acquisition system. Instead of having four DACs with their associated circuits, the DBK7 shares a single DAC among the four channels. Using the DAC this way makes the DBK7 more reliable, cost-efficient, and easier to calibrate. Each time the LogBook or Daq device addresses a different DBK7 channel, the DAC supplies the corresponding voltage (V_{out}) according to the formula:

$$V_{\text{out}} = 10.0 (D/4096) - 5.0 \text{ V}$$

Since DAC values (D) range from 0 to 4095, DBK7 output voltages range from -5.0000 to +4.9976 V.

Calibration for the DBK7 is automatic. When the DBK7 is initialized through software, its gain and offset errors are measured. The output circuits are then adjusted so the LogBook or Daq device measurements correspond to the DAC setting. The DBK7's software-adjustable gain and offset can correct for small errors in the DBK7 or the LogBook/Daq device. This automatic calibration eliminates the periodic need for manual calibration.

Specifications - DBK7

Name/Function: 4-Channel Frequency-to-Voltage Input Card

Input Channels per Card: 4

Maximum Cards per System: 64

Maximum Channels per System: 256

Input Connector: 1 BNC connector per channel

Connector: DB37 male, mates with P1

Frequency Ranges: (programmable) 0 Hz to 960 kHz

Output Voltage Range: -5 V to +5 V

Debounce Delays: (software selectable) 0, 0.6, 2.5, 10 ms

Measurement Rate: up to 500 per second per channel, 1000 per second total

Accuracy: 0.1%

Analog Input

Low-level:

50 mV typical (100 mV max) p-p sine wave @ 10 Hz to 100 kHz

Any edge of 50 (100 max) mV amplitude and 5 V/s rate.

Input impedance: AC-coupled (0.33 μ F), in series w/ 20 K Ω to ground.

15 mV hysteresis.

High-level:

0.75 V typical (1.25 V max) p-p sine wave @ 10 Hz to 100 kHz

Any edge of 0.75 V (1.25 V max) amplitude and 50 V/s rate.

Input impedance: AC-coupled (0.33 μ F), in series w/ 20 K Ω to ground.

250 mV hysteresis.

Maximum Input Voltage: 30 Vrms (84 Vp-p)

Low-Pass Filters: (hardware selectable) 30 Hz, 300 Hz, 100 kHz

Digital Input

TTL-Level: 0.001 to 960 kHz.

Input Impedance: 27 K Ω pull-up to +5 V || 50 pF

V Low ("0"): 0.8 V typ, 0.5 V min

V High ("1"): 1.6 V typ, 2.1 V max

Hysteresis: 400 mV min

Pulse Width (high or low): 520 nsec min.

Maximum Input Voltage: -15 V to +15 V

